

## Mediant™ 500L MSBR





---

## Table of Contents

---

|          |   |           |
|----------|---|-----------|
| <b>1</b> | <b>Introduction</b>                           | <b>11</b> |
| <b>2</b> | <b>Unpacking the Device</b>                   | <b>13</b> |
| <b>3</b> | <b>Physical Description</b>                   | <b>15</b> |
| 3.1      | Physical Dimensions and Operating Environment | 15        |
| 3.2      | Front Panel Description                       | 15        |
| 3.2.1    | LED Descriptions                              | 16        |
| 3.2.1.1  | Power LED                                     | 16        |
| 3.2.1.2  | Status LED                                    | 16        |
| 3.2.1.3  | Wi-Fi LED                                     | 17        |
| 3.2.1.4  | WAN LEDs                                      | 17        |
| 3.3      | Rear Panel Description                        | 19        |
| 3.3.1    | LAN Interface LEDs                            | 20        |
| <b>4</b> | <b>Orienting the Wi-Fi Antennas</b>           | <b>21</b> |
| 4.1      | Switching Wi-Fi On and Off                    | 21        |
| <b>5</b> | <b>Cabling the Device</b>                     | <b>23</b> |
| 5.1      | Connecting to WAN                             | 23        |
| 5.1.1    | Copper Gigabit Ethernet                       | 24        |
| 5.1.2    | Fiber-Optic Gigabit Ethernet                  | 25        |
| 5.1.3    | ADSL2+ and VDSL2                              | 26        |
| 5.1.4    | 3G/3.5G Cellular USB Modem                    | 28        |
| 5.2      | Connecting LAN Interfaces                     | 29        |
| 5.3      | ISDN BRI Interfaces                           | 30        |
| 5.3.1    | Connecting BRI Lines                          | 30        |
| 5.3.2    | Connecting PSTN Fallback for BRI Lines        | 32        |
| 5.4      | Analog Interfaces                             | 33        |
| 5.4.1    | Cabling FXS Interfaces                        | 33        |
| 5.4.2    | Cabling FXO Interfaces                        | 35        |
| 5.4.3    | Cabling the FXS Analog Lifeline               | 36        |
| 5.5      | Cabling the Serial Interface to a PC          | 37        |
| 5.6      | Connecting a USB Storage Device               | 38        |
| 5.7      | Connecting to the Power Supply                | 39        |
| 5.7.1    | 3-Amp Power Supply Cabling                    | 39        |
| 5.7.2    | 5-Amp Power Supply Cabling                    | 42        |
| 5.7.3    | Powering On or Off the Device                 | 42        |
| <b>A</b> | <b>Approved Laser SFPs</b>                    | <b>43</b> |

---

## List of Figures

---

|   |    |
|---|----|
| Figure 3-1: Front Panel.....                                      | 15 |
| Figure 4-1: Orienting Wi-Fi Antenna.....                          | 21 |
| Figure 5-1: Cabling the WAN Copper GbE Port.....                  | 24 |
| Figure 5-2: Removing Protective Dust Plug.....                    | 25 |
| Figure 5-3: Cabling the Fiber-Optic WAN GbE Port.....             | 26 |
| Figure 5-4: Cabling the xDSL WAN Port.....                        | 27 |
| Figure 5-5: Plugging the 3G Cellular Modem into the USB Port..... | 28 |
| Figure 5-6: Cabling LAN Ports.....                                | 29 |
| Figure 5-7: RJ-45 Connector Pinouts for BRI Ports.....            | 30 |
| Figure 5-8: Cabling BRI Ports.....                                | 31 |
| Figure 5-9: Cabling BRI PSTN Fallback.....                        | 32 |
| Figure 5-10: RJ-11 Connector Pinouts for FXS Interfaces.....      | 33 |
| Figure 5-11: Cabling FXS Interfaces.....                          | 34 |
| Figure 5-12: RJ-11 Connector Pinouts for FXO Interface.....       | 35 |
| Figure 5-13: Cabling FXO Interfaces.....                          | 35 |
| Figure 5-14: Cabling the FXS Analog Lifeline.....                 | 36 |
| Figure 5-15: RS-232 Cable Adapter.....                            | 37 |
| Figure 5-16: Cabling Serial Port.....                             | 37 |
| Figure 5-17: Connecting USB Storage Device.....                   | 38 |
| Figure 5-18: 3A AC/DC Power Adapter.....                          | 39 |
| Figure 5-19: Inserting Plug into Power Adapter.....               | 40 |
| Figure 5-20: Cabling to Power with 3A AC/DC Power Adapter.....    | 41 |
| Figure 5-21: Cabling to Power with 5A AC/DC Power Adapter.....    | 42 |

---

## List of Tables

---

|  |    |
|--|----|
| Table 3-1: Physical Dimensions and Operating Environment ..... | 15 |
| Table 3-2: Front Panel Description .....                       | 16 |
| Table 3-3: Power LED Description .....                         | 16 |
| Table 3-4: Status LED Description .....                        | 16 |
| Table 3-5: Wi-Fi LED Description .....                         | 17 |
| Table 3-6: WAN GE LED Description .....                        | 17 |
| Table 3-7: WAN SFP LED Description .....                       | 17 |
| Table 3-8: WAN A/VDSL LED Description .....                    | 18 |
| Table 3-9: Front Panel Description .....                       | 19 |
| Table 3-10: LAN LED Description.....                           | 20 |
| Table 5-1: RJ-45 Connector Pinouts for Copper GbE WAN .....    | 24 |
| Table 5-2: RJ-11 Connector Pinouts for xDSL .....              | 27 |
| Table 5-3: RJ-45 Connector Pinouts for FE .....                | 29 |
| Table 5-4: RJ-45 to DB-9 Serial Cable Connector Pinouts .....  | 37 |
| Table 5-5: Power Specifications .....                          | 39 |
| Table 5-6: Power Adapter with Interchangeable Plugs .....      | 40 |
| Table A-1: Approved SFP Modules .....                          | 43 |

**This page is intentionally left blank.**

## Notice

This Hardware Installation Manual describes the hardware installation of AudioCodes **Mediant 500L Multi-Service Business Router** (MSBR).

Information contained in this document is believed to be accurate and reliable at the time of printing. However, due to ongoing product improvements and revisions, AudioCodes cannot guarantee accuracy of printed material after the Date Published nor can it accept responsibility for errors or omissions.

Before consulting this document, check the corresponding Release Notes regarding feature preconditions and/or specific support in this release. In cases where there are discrepancies between this document and the Release Notes, the information in the Release Notes supersedes that in this document. Updates to this document and other documents as well as software files can be downloaded by registered customers at <http://www.audiocodes.com/downloads>.

© Copyright 2016 AudioCodes Ltd. All rights reserved.

This document is subject to change without notice.

Date Published: July-03-2016

## Trademarks

AudioCodes, AC, HD VoIP, HD VoIP Sounds Better, IPmedia, Mediant, MediaPack, What's Inside Matters, OSN, SmartTAP, VMAS, VoIPerfect, VoIPerfectHD, Your Gateway To VoIP, 3GX, VocaNOM and CloudBond 365 are trademarks or registered trademarks of AudioCodes Limited. All other products or trademarks are property of their respective owners. Product specifications are subject to change without notice.

## WEEE EU Directive

Pursuant to the WEEE EU Directive, electronic and electrical waste must not be disposed of with unsorted waste. Please contact your local recycling authority for disposal of this product.

## Customer Support

Customer technical support and services are provided by AudioCodes or by an authorized AudioCodes Service Partner. For more information on how to buy technical support for AudioCodes products and for contact information, please visit our Web site at [www.audiocodes.com/support](http://www.audiocodes.com/support).

## Abbreviations and Terminology

Each abbreviation, unless widely used, is spelled out in full when first used.

Throughout this manual, unless otherwise specified, the term *device* refers to Mediant 500L MSBR.

## Related Documentation

| Document Name                   |
|---------------------------------|
| SIP Release Notes               |
| Mediant 500L MSBR User's Manual |
| CLI Reference Guide             |

## General Notes and Warnings, and Safety Information



**Note:** Open source software may have been added and/or amended for this product. For further information, please visit our website at <http://audiocodes.com/support> or contact your AudioCodes sales representative.



**Warning:** The device is an **INDOOR** unit and therefore, must be installed **only** indoors.



### Caution Electrical Shock

Do not open or disassemble this device. The device carries high voltage and contact with internal components may expose you to electrical shock and bodily harm.



**Warning:** The device must be installed and serviced only by qualified service personnel.



**Warning:** For deployment in Finland, Sweden and Norway, the device must be installed **only** in restricted access locations that are compliant with ETS 300253 guidelines where equipotential bonding has been implemented.



**Warning:** Disconnect the device from the mains and Telephone Network Voltage (TNV) before servicing.



## Document Revision Record

| LTRT  | Description                   |
|-------|-------------------------------|
| 10443 | A/VDSL LEDs updated.          |
| 10444 | DSL connector pinouts updated |

## Documentation Feedback

AudioCodes continually strives to produce high quality documentation. If you have any comments (suggestions or errors) regarding this document, please fill out the Documentation Feedback form on our Web site at <http://www.audiocodes.com/downloads>. Your valuable feedback is highly appreciated.

**This page is intentionally left blank.**

# 1 Introduction

This document provides a hardware description of the Mediant 500 MSBR (hereafter referred to as *device*) and step-by-step procedures for mounting and cabling the device.

The device supports the following interfaces:

- Multiple WAN, depending on ordered configuration:
  - Single Gigabit Ethernet copper (10/100/1000Base-T) unshielded twisted pair (UTP) interface port
  - Dual-mode of 1.25 Gbps Optical Fiber Small Form-Factor Pluggable (SFP)
  - ADSL2+ / VDSL2
  - 3G Cellular WAN access (primary or backup), using a USB modem
- Four Fast Ethernet (10/100Base-T) LAN ports (RJ-45).
- One USB port for optional USB storage services and 3G cellular WAN modem.
- Optional PSTN telephony interfaces:
  - Up to four FXS port interfaces
  - Up to four FXO port interfaces
  - Two ISDN BRI port interfaces, supporting up to four voice channels as well as PSTN fallback
- (Optional) Wireless LAN 802.11n/b/g (Wi-Fi) access point, providing two integrated, multiple-input and multiple-output (MIMO) 2Tx/2Rx antennas that operate in the 2.4 GHz frequency range.
- Serial console port (RJ-45) for device management

**Notes:**

- Hardware configurations may change without notice. Currently available hardware configurations are listed in AudioCodes Price Book. For further enquiries, please contact your AudioCodes sales representative.
- For information on configuring the device, refer to the device's *User's Manual*.

**This page is intentionally left blank.**

## 2 Unpacking the Device

Follow the procedure below for unpacking the carton in which the device was shipped.

➤ **To unpack the device:**

1. Open the carton and carefully remove packing materials.
2. Remove the chassis from the carton.
3. Check that there is no equipment damage.
4. Ensure that in addition to the chassis, the package contains the following items:
  - Four anti-slide bumpers for desktop installation
  - Two mounting brackets for 19-inch rack mounting (customer-ordered item)
  - Two Wi-Fi antennas (depending on ordered model)
  - Serial cable adapter
  - AC/DC power adapter
5. Check, retain and process any documents.

If there are any damaged or missing items, notify your AudioCodes sales representative.

**This page is intentionally left blank.**

## 3 Physical Description

This section provides a physical description of the device.

### 3.1 Physical Dimensions and Operating Environment

The device's physical dimensions and operating environment are listed in the table below:

**Table 3-1: Physical Dimensions and Operating Environment**

| Specification                 | Value  |
|-------------------------------|--|
| <b>Dimensions (H x W x D)</b> | 51 x 296 x 165 mm (2 x 11.65 x 6.5 in.)  |
| <b>Weight</b>                 | 670 g (1.5 lbs.)   |
| <b>Operating Environment</b>  | <ul style="list-style-type: none"> <li>▪ Operational: 5 to 40°C (41 to 104°F)</li> <li>▪ Storage: -25 to 85°C (-13 to 185°F)</li> <li>▪ Relative Humidity: 10 to 90% non-condensing</li> </ul> |

### 3.2 Front Panel Description

The front panel provides LEDs for indicating the status of various functionalities. The LEDs are shown in the figure below and described in the subsequent tables.

**Figure 3-1: Front Panel**



**Note:** The figure above is used only as an example. The available LEDs depend on the ordered hardware configuration.

**Table 3-2: Front Panel Description**

| Item # | LED Label         | Description  |
|--------|-------------------|--|
| 1      | <b>Power</b>      | Indicates the status of the power supply to the device. For more information, see Section 3.2.1 on page 16.  |
| 2      | <b>Status</b>     | Indicates the operating status of the device. For more information, see Section 3.2.1.2 on page 16.  |
| 3      | <b>Wi-Fi</b>      | Indicates the operating status of the wireless LAN interface. . For more information, see Section 3.2.1.3 on page 17.<br><b>Note:</b> The LED is available only on models ordered with wireless LAN functionality. |
| 4      | <b>WAN GE</b>     | Indicates the status of the Gigabit Ethernet WAN connection. For more information, see Section 3.2.1.4 on page 17.   |
| 5      | <b>WAN SFP</b>    | Indicates the status of the optical fiber WAN connection. For more information, see Section 3.2.1.4.2 on page 17.  |
| 6      | <b>WAN A/VDSL</b> | Indicates the status of the A/VDSL WAN connection. For more information, see Section 3.2.1.4.3 on page 18.   |

## 3.2.1 LED Descriptions

### 3.2.1.1 Power LED

The **Power** LED indicates the operating status, as described in the table below.

**Table 3-3: Power LED Description**

| LED Color    | LED State | Description                         |
|--------------|-----------|-------------------------------------|
| <b>Green</b> | On        | Power is received by the device.    |
| -            | Off       | No power is received by the device. |

### 3.2.1.2 Status LED

The **Status** LED indicates the operating status, as described in the table below.

**Table 3-4: Status LED Description**

| LED Color    | LED State | Description               |
|--------------|-----------|---------------------------|
| <b>Green</b> | On        | Device is operational.    |
|              | Flashing  | Initial rebooting stage.  |
| <b>Red</b>   | On        | Boot failure.             |
| -            | Off       | Advanced rebooting stage. |



### 3.2.1.3 Wi-Fi LED

The **Wi-Fi** LED indicates the Wi-Fi link status, as described in the table below.

**Table 3-5: Wi-Fi LED Description**

| LED Color | LED State | Description                  |
|-----------|-----------|------------------------------|
| Green     | On        | Wi-Fi is activated.          |
|           | Flashing  | Traffic on the wireless LAN. |
| -         | Off       | Wi-Fi is not configured.     |

### 3.2.1.4 WAN LEDs

#### 3.2.1.4.1 GE WAN LED

The **WAN GE** LED indicates the status of the Gigabit Ethernet (copper) WAN link, as described in the table below.

**Table 3-6: WAN GE LED Description**

| LED Color | LED State | Description   |
|-----------|-----------|---|
| Green     | On        | WAN GE link established.                            |
|           | Flashing  | Data is being received or transmitted.              |
| -         | Off       | No WAN GE link or power not received by the device. |

#### 3.2.1.4.2 SFP WAN LED

The **WAN SFP** LED indicates the status of the optical fiber WAN link, as described in the table below.

**Table 3-7: WAN SFP LED Description**

| LED Color | LED State | Description  |
|-----------|-----------|--|
| Green     | On        | WAN fiber link established.                            |
|           | Flashing  | Data is being received or transmitted.                 |
| -         | Off       | No WAN fiber link or power not received by the device. |

### 3.2.1.4.3 A/VDSL WAN LED

The **WAN A/VDSL** LED indicates the status of the A/VDSL WAN link, as described in the table below.

**Table 3-8: WAN A/VDSL LED Description**

| LED Color    | LED State                                | Description   |
|--------------|--|---|
| <b>Green</b> | On                                       | DSL link connected (trained) successfully with peer ("showtime").               |
|              | Fast Flashing                            | Training up (connection in progress) and negotiating with peer.                 |
|              | Slow Flashing                            | DSL port is administratively up, but idle (not connected and no peer detected). |
|              | Two Fast Flashes and then Idle Sequences | DSL port is initializing itself after being enabled or upon mode change.        |
| -            | Off                                      | DSL port is administratively shutdown or not configured.                        |

### 3.3 Rear Panel Description

The device's rear panel is shown in the figure below and described in the subsequent table.

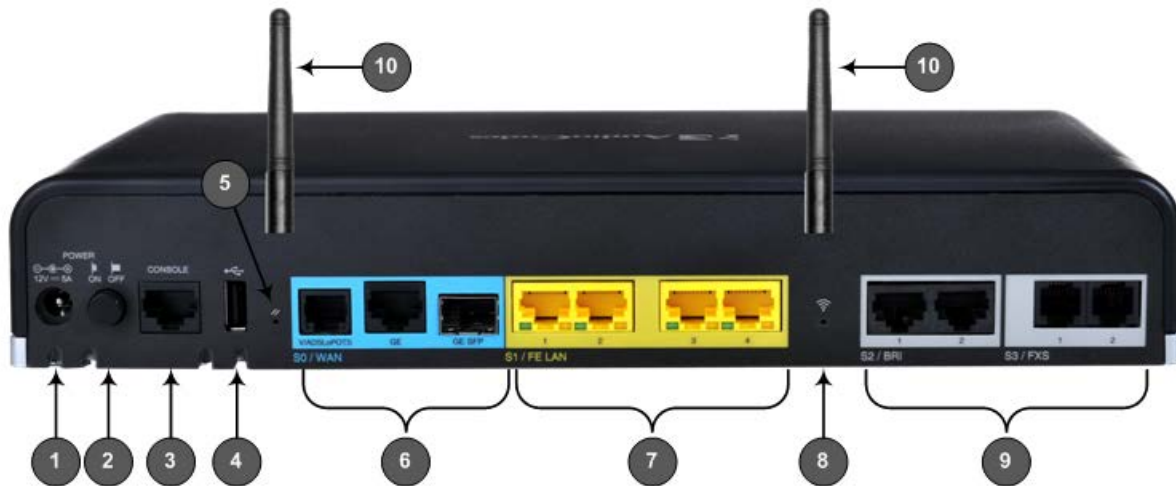

**Note:** The figure above is used only as an example. The hardware configuration depends on the ordered model.

**Table 3-9: Front Panel Description**

| Item # | Label   | Description   |
|--------|---|---|
| 1      | <b>POWER<br/>12V -- 5A</b>  | AC power supply plug entry for connecting the device to the external AC power supply adapter.   |
| 2      | <b>ON / OFF</b>   | Power button which powers on the device when pressed in and powers off the device when pressed again (pressed out).   |
| 3      | <b>CONSOLE</b>  | RJ-45 port for RS-232 serial communication with the device.   |
| 4      |  | USB 2.0 port, which can be used for the following: <ul style="list-style-type: none"> <li>3G cellular WAN modem for primary or backup WAN</li> <li>External USB hard drive or flash disk (disk on key) for USB storage capabilities (for example, for configuration file)</li> </ul>  |
| 5      | //  | Reset pinhole button for resetting the device or for restoring it to factory defaults. To restore the device to factory defaults, do the following:<br>With a paper clip or any other similar pointed object, press and hold down the pinhole button for <b>at least 12 seconds, but no longer than 25 seconds</b>  |
| 6      | <b>WAN</b>  | WAN interface ports, which can be any of the following (depending on ordered configuration): <ul style="list-style-type: none"> <li><b>GE:</b> Copper GE</li> <li><b>GE SFP:</b> SFP module - dual-mode supporting 1.25 Gbps</li> <li><b>V/ADSLoPOTS:</b> ADSL/2+ and VDSL2</li> </ul> <b>Note:</b> For available WAN configurations, contact your AudioCodes |

| Item # | Label   | Description  |
|--------|---|--|
|        |   | sales representative.  |
| 7      | <b>FE LAN</b>   | Up to four Fast Ethernet (10/100Base-T) ports (RJ-45) for connecting to LAN network such as IP phones, computers, and switches. These ports support half- and full-duplex modes, auto-negotiation, and straight or crossover cable detection.                                |
| 8      |  | Wi-Fi pinhole button for enabling and disabling Wi-Fi. Use a paper clip or any other similar pointed object to press the button.<br><b>Note:</b> The Wi-Fi button is available only for models ordered with the Wi-Fi functionality.   |
| 9      | <b>FXS / FXO / BRI</b>  | Telephony interfaces, depending on ordered configuration: <ul style="list-style-type: none"> <li>▪ Up to two ISDN BRI port interfaces (RJ-45)</li> <li>▪ Up to four FXS port interfaces (RJ-11)</li> <li>▪ Up to four FXO port interfaces (RJ-11)</li> </ul>                 |
| 10     | -   | Multiple-input and multiple-output (MIMO) 2Tx/2Rx antennas, operating in the 2.4 GHz frequency range for wireless LAN 802.11n/b/g (Wi-Fi) access point functionality.<br><b>Note:</b> The Wi-Fi antennas are applicable only to models ordered with the Wi-Fi functionality. |

### 3.3.1 LAN Interface LEDs

Each Ethernet port provides a LED for indicating LAN operating status, as described in the table below.

**Table 3-10: LAN LED Description**

| LED Color | LED State | Description                            |
|-----------|-----------|--|
| Green     | On        | Ethernet link established.             |
|           | Flashing  | Data is being received or transmitted. |
| -         | Off       | No Ethernet link.                      |

## 4 Orienting the Wi-Fi Antennas

If you have ordered LAN wireless (Wi-Fi) functionality, the device is shipped with two pre-attached, external Wi-Fi antennas. You can orient the antennas in the vertical plane, from 0 to 180 degrees for optimal wireless transmission and reception. For best performance, it is recommended that the antennas be perpendicular (90 degrees) to the floor. In other words, orient the antennas straight up.

Figure 4-1: Orienting Wi-Fi Antenna

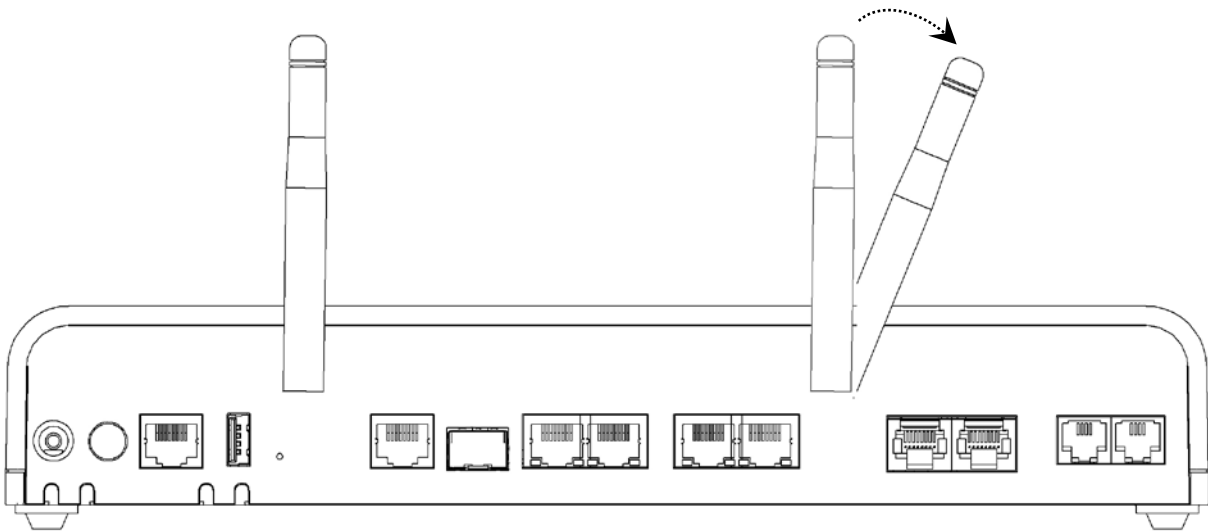

**Note:** This section is applicable only for models ordered with the Wi-Fi functionality.

### 4.1 Switching Wi-Fi On and Off

The wireless LAN interface can be turned on or off by pressing the Wi-Fi pinhole button located on the rear panel (see Section 3.3 on page 19).

**This page is intentionally left blank.**

## 5 Cabling the Device

This chapter describes the cabling of the device, which includes the following:

- Connecting WAN interfaces – see Section 5.1 on page 23
- Connecting LAN interfaces – see Section 5.2 on page 29
- Connecting BRI lines – see Section 5.3.1 on page 30
- Connecting the PSTN Fallback for BRI Lines – see Section 5.3.2 on page 32
- Connecting FXS interfaces – see Section 5.4.1 on page 33
- Connecting FXO interfaces – see Section 5.4.2 on page 35
- Connecting the FXS Analog Lifeline – see Section 5.4.3 on page 36
- Connecting the serial interface – see Section 5.5 on page 37
- Connecting a USB storage device – see Section 5.6 on page 29
- Connecting to power – see Section 5.7 on page 39

### 5.1 Connecting to WAN

This section provides a description on how to cable the WAN port. The cabling procedure depends on the WAN interface:

- Copper Gigabit Ethernet (GbE) – see Section 5.1.1 on page 24
- Fiber-optic GbE – see Section 5.1.2 on page 25
- ADSL2+ and VDSL2 – see Section 5.1.3 on page 26
- 3G Cellular USB modem – see Section 5.1.4 on page 28



**Note:** The device supports WAN redundancy, whereby multiple WAN interfaces can serve as backups for the primary or a backup WAN interface. For example, if the main WAN interface is Copper GbE and it fails, the device switches over to the fiber-optic WAN interface. If this WAN interface also fails, the device switches over to the 3G WAN interface, and so on. For configuring WAN redundancy, refer to the *CLI Reference Guide*.

## 5.1.1 Copper Gigabit Ethernet

The device provides a copper Gigabit Ethernet (GbE) port interface for connecting to the WAN.

Cable specification:

- **Cable:** straight-through Cat 5 cable
- **Connector:** RJ-45
- **Connector Pinouts:**

**Table 5-1: RJ-45 Connector Pinouts for Copper GbE WAN**

| Pin | Signal Name          |
|-----|----------------------|
| 1   | Ethernet signal pair |
| 2   |                      |
| 3   | Ethernet signal pair |
| 6   |                      |
| 4   | Ethernet signal pair |
| 5   |                      |
| 7   | Ethernet signal pair |
| 8   |                      |

➤ **To connect the copper GbE WAN port:**

1. Connect one end of a straight-through RJ-45 Ethernet cable to the RJ-45 port labeled **S0 / WAN GE** (located on the front panel).

**Figure 5-1: Cabling the WAN Copper GbE Port**

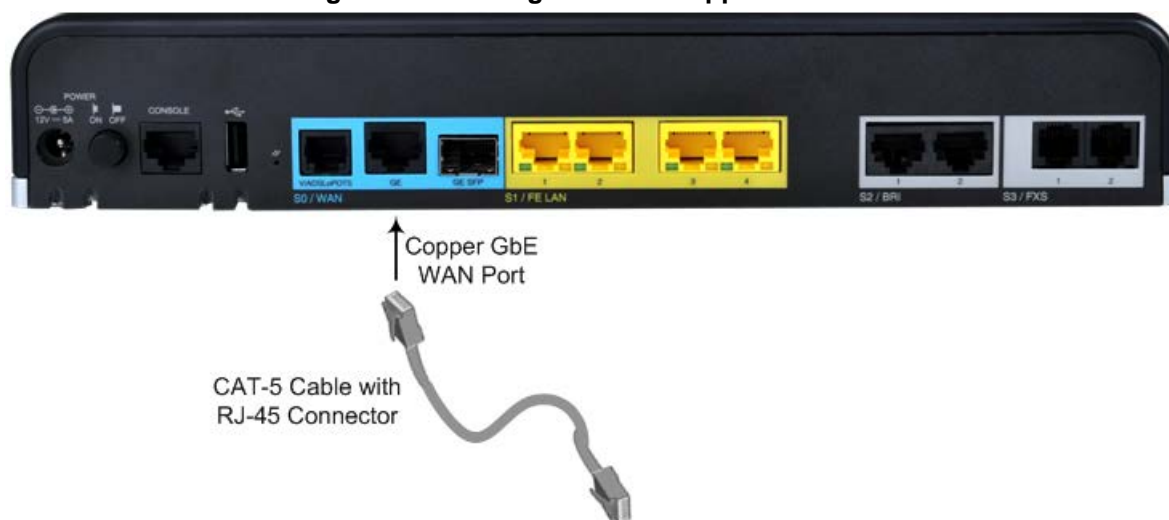

2. Connect the other end of the cable to the WAN network (e.g., ADSL or Cable modem).



## 5.1.2 Fiber-Optic Gigabit Ethernet

The device supports up to two pairs of 1.25 Gbps optical, small form-factor pluggable (SFP) transceiver modules (see note below).



### Caution Laser

This device contains a Class 1 LED/Laser emitting device, as defined by 21CFR 1040 and IEC825. Do not stare directly into the beam or into fiber optic terminations as this can damage your eyesight.



### Care in Handling Fiber Optic Cabling

1. Excessive bending of the Fiber Optic Cable can cause distortion and signal losses.
2. Ensure the minimum bending radius recommended by the Fiber Optic Cable supplier.
3. Incoming optic cabling from the network infrastructure can originate from the top of the rack or from another shelf within the rack. Preserve the minimum-bending ratio indicated by the cable manufacturer.
4. To ensure full high-availability capabilities, the configuration of the interface to the IP backbone must include certain redundant features from which two separate fiber optic cables are entering the device.



### Notes:

- The SFP module and fiber-optic cable are not supplied. It is recommended that you purchase the SFP modules from AudioCodes. For a list of orderable SFP modules, see Appendix A on page 43, or contact your AudioCodes sales representative.
- This AudioCodes device has been evaluated with the laser transceiver modules (SFP) listed in Appendix A on page 43. If other SFP modules are used, the person installing the device is solely responsible for the usage of correct SFP modules to comply with local, applicable laser safety requirements and certification. AudioCodes will not be held responsible for any damage to human body or equipment caused as a result from the usage of SFP modules that are not listed in Appendix A on page 43.

### ➤ To connect the fiber-optic WAN GbE port:

1. Remove the protective dust plug from the SFP transceiver module. Save the dust plugs for future use.

**Figure 5-2: Removing Protective Dust Plug**



2. Immediately connect a cable with LC-type plugs to the SFP transceivers (labeled **GE SFP**).

**Figure 5-3: Cabling the Fiber-Optic WAN GbE Port**

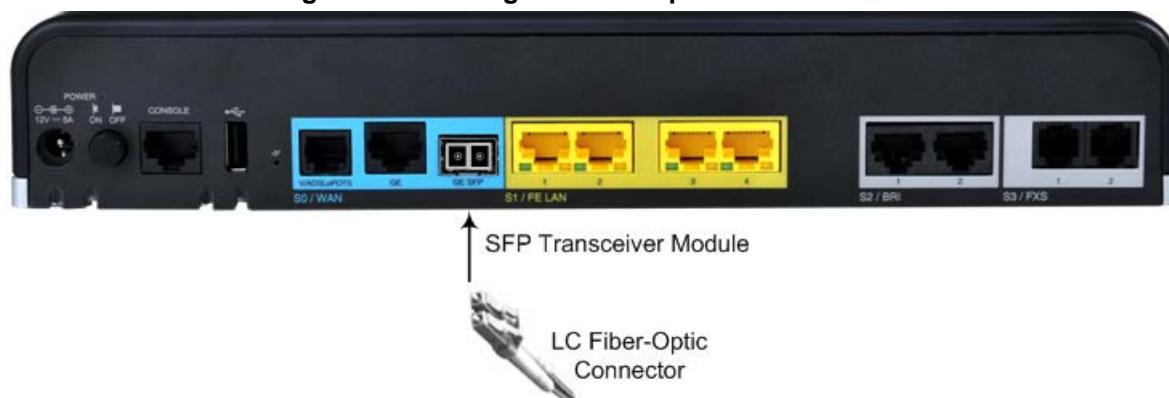

3. Connect the other end of the cable to the fiber network.

### 5.1.3 ADSL2+ and VDSL2

The ADSL2+ and VDSL2 (xDSL) WAN port provides a single xDSL interface through an RJ-11 port. The specifications of the xDSL interface include the following:

- ADSL2+:
  - RFC 2684 in Routed (IPoA) and Bridged (ETHoA) modes, supporting LLC-SNAP and VC-Multiplexed encapsulations over AAL5
  - ATM UNI 4.1 compliant
  - UBR, CBR, VBR classes of service
  - RFC 2364 PPPoA
  - RFC 2516 PPPoE over ATM
  - Up to 8 PVCs
- VDSL2:
  - ITU G.991.2 Annex E for Ethernet, also known as EFM or 2Base-TL, as defined in IEEE 802.3ah
  - 802.1q VLANs over EFM
  - PPPoE



**Note:** The xDSL interface is a customer-ordered item which is supported only on specific hardware configurations. For more information, contact your AudioCodes sales representative.

Cable specification:

- **Connector:** RJ-11
- **Connector Pinouts:**

**Table 5-2: RJ-11 Connector Pinouts for xDSL**

| Pin | Function      |
|-----|---------------|
| 3   | CH0 – P/TIP   |
| 4   | CH0 – N/RING  |
| 1   | Not connected |
| 2   | Not connected |
| 5   | Not connected |
| 6   | Not connected |

➤ **To connect the WAN xDSL port:**

1. Connect an RJ-11 cable connector to the device’s xDSL WAN port (labeled V/ADSLoPOTS).

**Figure 5-4: Cabling the xDSL WAN Port**

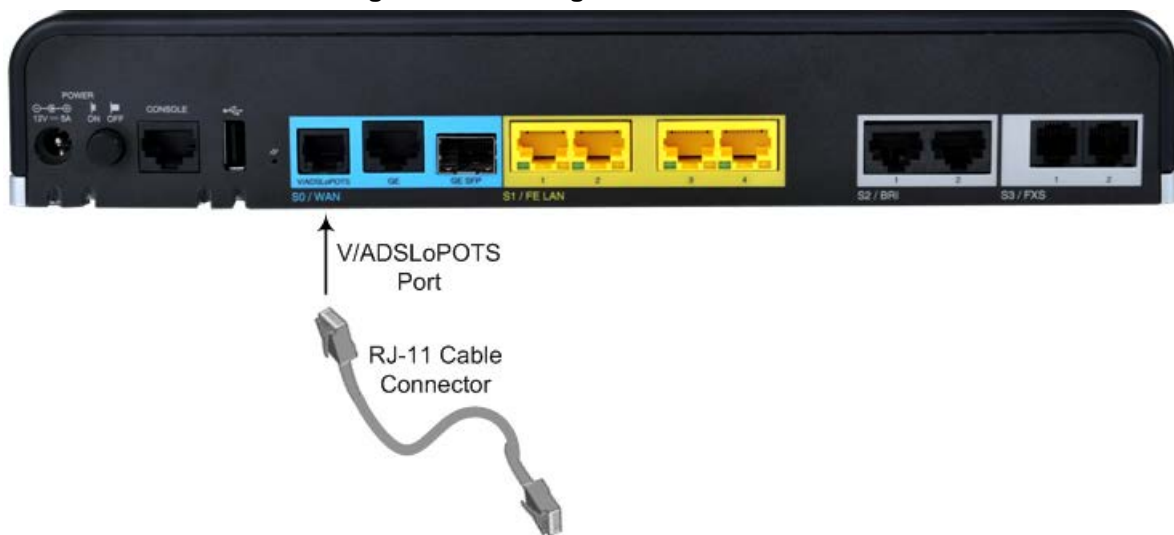

2. Connect the other end of the cable to the access point.



**Note:** The xDSL filter/splitter is not supplied and should be provided by your service provider.

## 5.1.4 3G/3.5G Cellular USB Modem

The device supports a 3G cellular WAN interface using a USB-based 3G cellular modem. The 3G cellular WAN interface can be used as the primary WAN interface or as an optional WAN backup when the primary WAN (e.g., WAN Ethernet) fails. The WAN connection type is a point-to-point protocol (PPP) over cellular.



**Note:** To verify whether your third-party, 3G cellular modem is supported by the device, please provide the modem's model details to your AudioCodes sales representative.

➤ **To connect the 3G cellular WAN modem:**

- Plug a 3G cellular USB modem into the USB port, located on the rear panel:

**Figure 5-5: Plugging the 3G Cellular Modem into the USB Port**

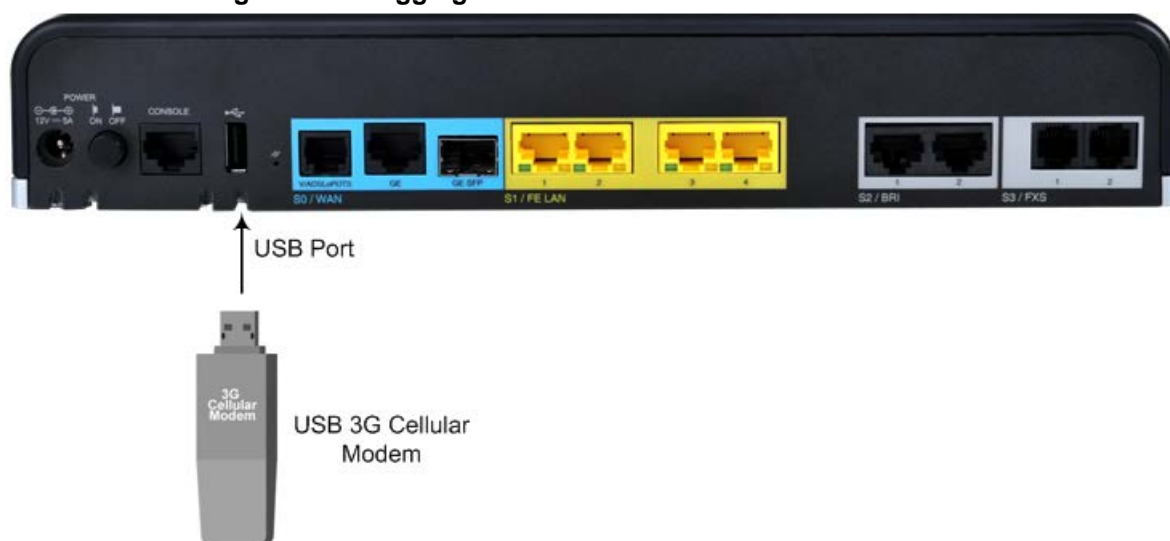

For configuring 3G cellular WAN, refer to the *User's Manual*.

## 5.2 Connecting LAN Interfaces

The device's Fast Ethernet LAN ports (10/100Base-T) can be connected to network equipment and entities such as computers, switches, and IP phones. These ports support half- and full-duplex modes, auto-negotiation, and straight or crossover cable detection.

Cable specification:

- **Cable:** straight-through Cat 5e or Cat 6 cable
- **Connector:** RJ-45
- **Connector Pinouts:**

**Table 5-3: RJ-45 Connector Pinouts for FE**

| Pin | Signal Name                         |
|-----|-------------------------------------|
| 1   | Ethernet signal pair (10/100Base-T) |
| 2   |                                     |
| 3   | Ethernet signal pair (10/100Base-T) |
| 6   |                                     |

➤ **To connect the device to the LAN:**

1. Connect one end of a straight-through RJ-45 Cat 5e or Cat 6 cable to the LAN port, located on the rear panel and labeled **FE LAN**.

**Figure 5-6: Cabling LAN Ports**

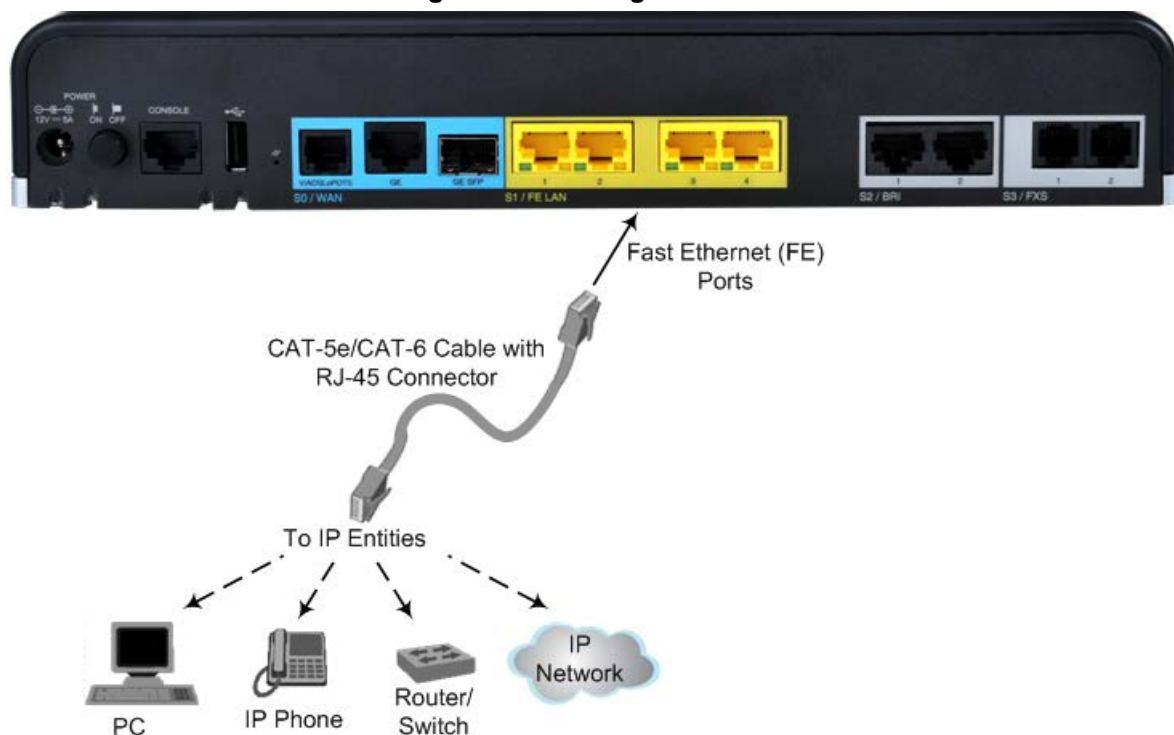

2. Connect the other end of the cable to a network device or entity.

## 5.3 ISDN BRI Interfaces

This section describes how to connect the device to ISDN BRI lines.

### 5.3.1 Connecting BRI Lines

The BRI ports can be connected to ISDN terminal equipment such as ISDN telephones or PBXs. Each BRI port can be configured either as termination equipment/user side (TE) or network termination/network side (NT). Up to eight terminal equipment (TE) devices can be connected per BRI S/T port, using an ISDN S-bus providing eight ISDN ports. When configured as NT, the BRI port drives a nominal voltage of 38V with limited current supply of up to 100 mA.



**Warning:** To protect against electrical shock and fire, use a 26 AWG min. wire to connect the BRI ports to the PSTN.



**Note:** BRI interface is a customer-ordered item which is supported only on specific hardware configurations. For more information, contact your AudioCodes sales representative.

Cable specification:

- **Cable:** 26 AWG min. wire
- **Connector:** RJ-45
- **Connector Pinouts:**

**Figure 5-7: RJ-45 Connector Pinouts for BRI Ports**

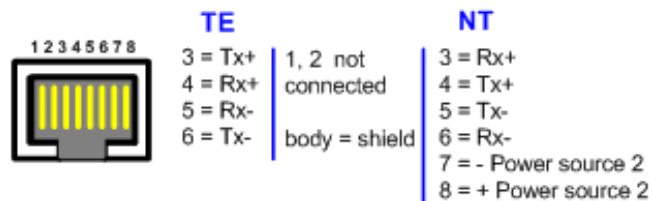

➤ **To connect a BRI line:**

1. Connect the RJ-45 cable to the device's BRI port, located on the rear panel and labeled **BRI**.

**Figure 5-8: Cabling BRI Ports**

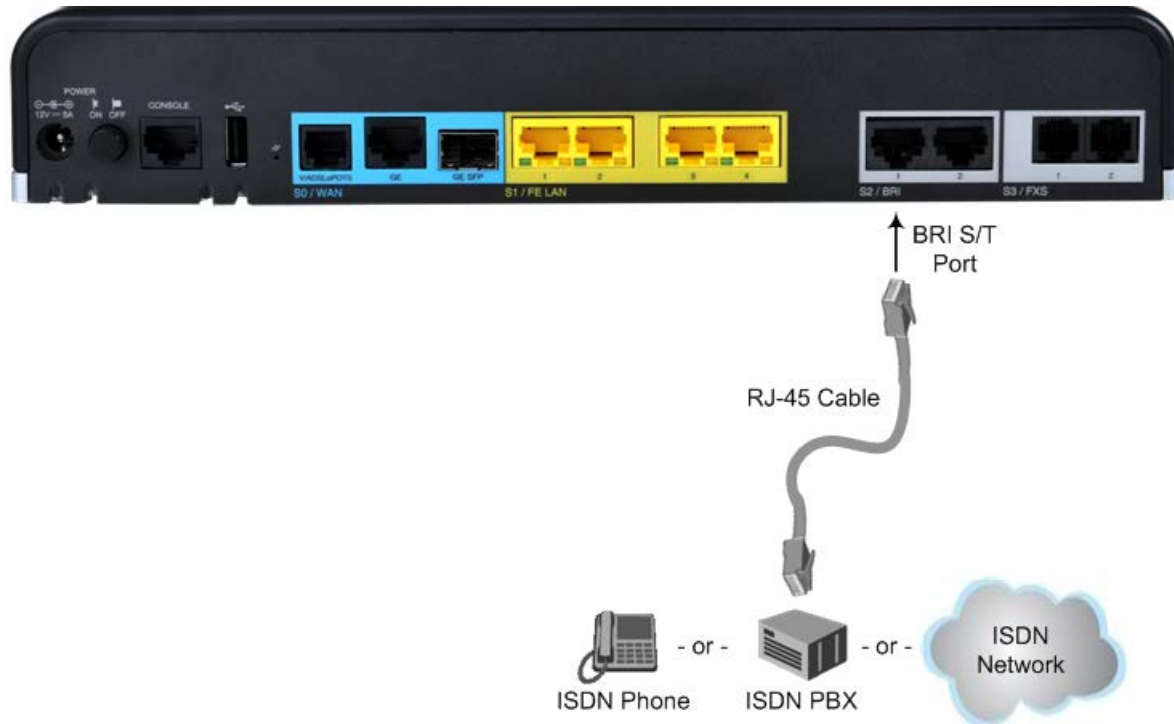

2. Connect the other end of the cable to your ISDN equipment.

### 5.3.2 Connecting PSTN Fallback for BRI Lines

The device's BRI PSTN Fallback feature provides a wired connection for an ISDN BRI phone or PBX (line), connected to the device's BRI port, to the ISDN network, upon a power outage or IP network connectivity loss (i.e., no ping to network).

The BRI PSTN Fallback uses BRI ports #1 and #2. When the BRI PSTN Fallback is activated, the BRI port #1 metallic relay switch automatically connects BRI ports #1 and #2, and calls can be routed and established between these entities.

➤ **To cable the BRI PSTN Fallback:**

1. Connect BRI line 1 (Port #1), located on the rear panel, to an ISDN PBX.
2. Connect BRI line 2 (Port #2), located on the rear panel, to the ISDN network (PSTN).

**Figure 5-9: Cabling BRI PSTN Fallback**

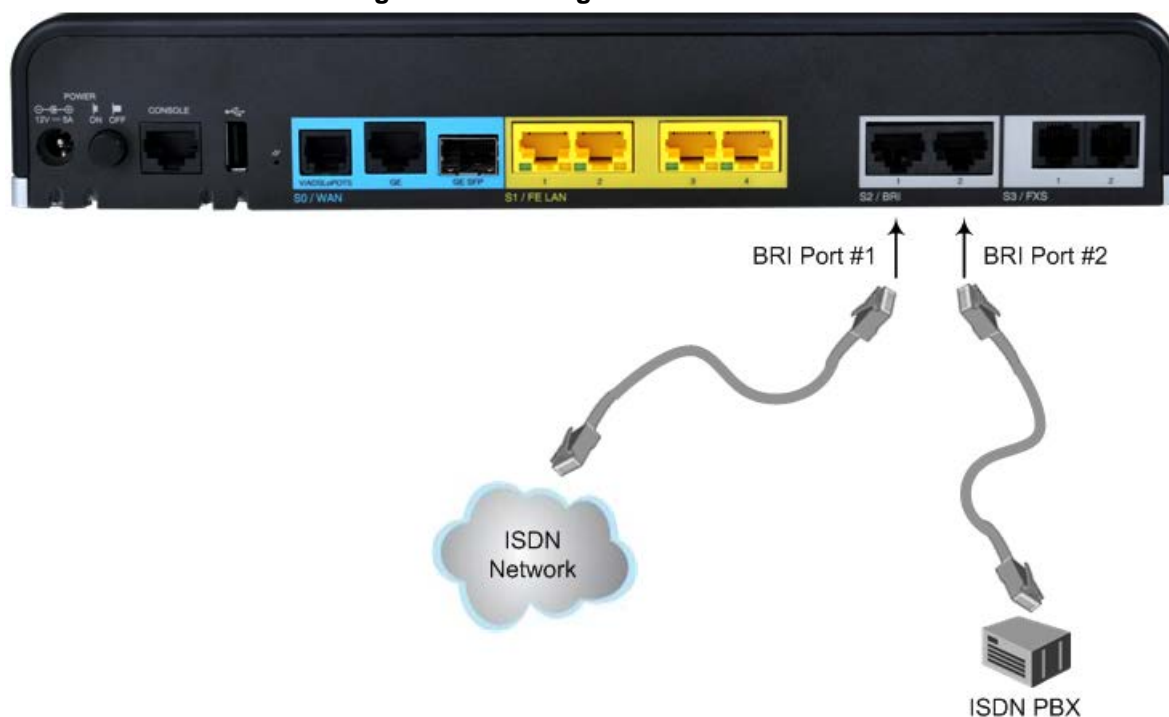

**Notes:**

- The BRI PSTN Fallback feature is a customer-ordered item, which is supported only on specific hardware configurations providing BRI interfaces. For more information, contact your AudioCodes sales representative.
- The scenarios upon which the BRI PSTN Fallback is activated (i.e., power outage and/or IP network loss) are configured by the TrunkLifeLineType parameter. For more information, refer to the *User's Manual*.
- The BRI PSTN Fallback feature has no relation to the PSTN Fallback Software License Key.





## 5.4 Analog Interfaces

This section describes how to connect the device to analog equipment.

### 5.4.1 Cabling FXS Interfaces

The procedure below describes how to cable the device's FXS interfaces. FXS is the interface replacing the Exchange—Central Office (CO) or Private Branch Exchange (PBX)—and connects to analog telephones, dial-up modems, and fax machines. The FXS is designed to supply line voltage and ringing current to these telephone devices.



#### Warnings:

- The device is an **INDOOR** unit and thus, must be installed and located only indoors.
- Ensure that the FXS ports are connected to the appropriate, external devices; otherwise, damage to the device may occur.
- FXS ports are considered TNV-2.



#### Notes:

- FXS interface is a customer-ordered item which is supported only on specific hardware configurations. For more information, contact your AudioCodes sales representative.
- The FXS/FXO interfaces support loop-start signaling (indoor only).

Cable specification:

- **Cable:** Standard straight-through RJ-11 telephony cable
- **Connector:** RJ-11
- **Connector Pinouts:**

**Figure 5-10: RJ-11 Connector Pinouts for FXS Interfaces**

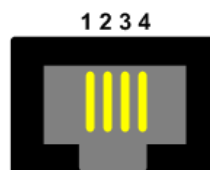

- 1 - Not connected
- 2 - Tip
- 3 - Ring
- 4 - Not connected

➤ **To connect an FXS interface:**

1. Connect one end of an RJ-11 cable to an FXS port, located on the rear panel and labeled **FXS**.

**Figure 5-11: Cabling FXS Interfaces**

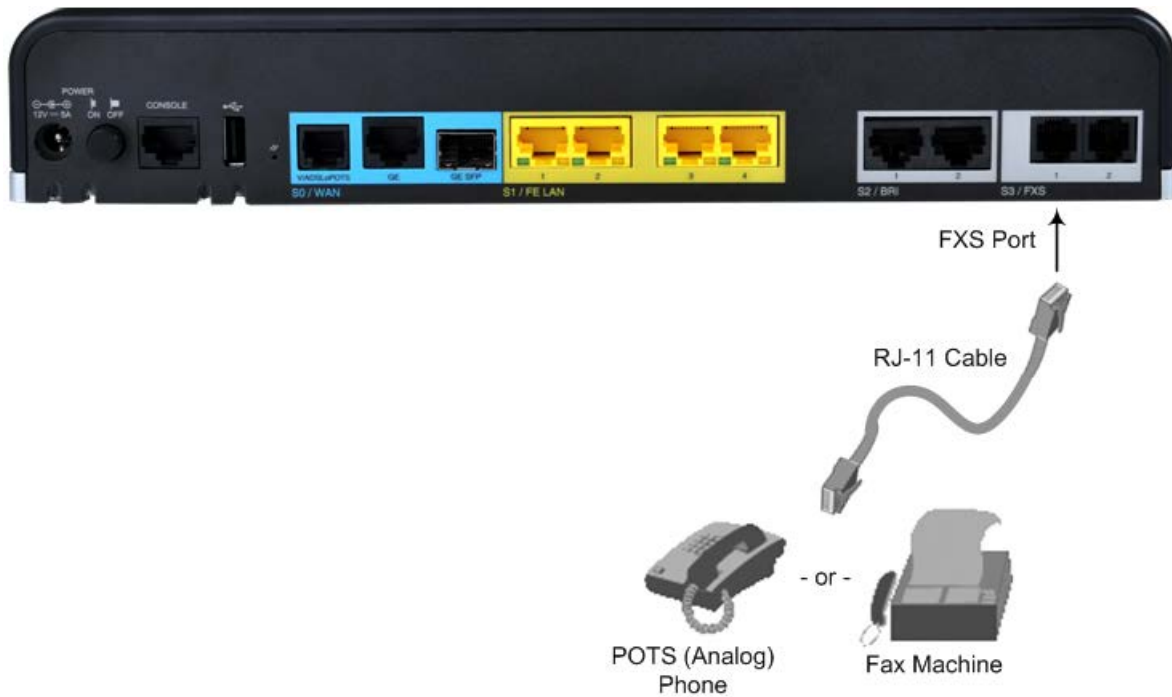

2. Connect the other end of the cable to the required telephone interface (e.g., fax machine, dial-up modem, or analog POTS telephone).

## 5.4.2 Cabling FXO Interfaces

The procedure below describes how to cable the device's FXO interface. FXO is the interface replacing the analog telephone and connects to a Public Switched Telephone Network (PSTN) line from the CO or to a PBX. The FXO is designed to receive line voltage and ringing current, supplied from the CO or the PBX (similar to an analog telephone).



### Warnings:

- To protect against electrical shock and fire, use a minimum 26-AWG wire to the connect FXO port to the PSTN.
- Make sure that the FXO port is connected to the appropriate, external device; otherwise, damage to the device may occur.
- The FXO port is considered TNV-3.



**Note:** FXO interface is a customer-ordered item which is supported only on specific hardware configurations. For more information, contact your AudioCodes sales representative.

Cable specification:

- **Cable:** 26-AWG wire
- **Connector:** RJ-11
- **Connector Pinouts:**

Figure 5-12: RJ-11 Connector Pinouts for FXO Interface

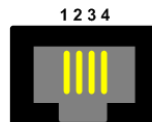

- 1 - Not connected
- 2 - Tip
- 3 - Ring
- 4 - Not connected

### ➤ To connect an FXO interface:

1. Connect one end of an RJ-11 cable to an FXO port, located on the rear panel and labeled **FXO**.

Figure 5-13: Cabling FXO Interfaces



2. Connect the other end of the cable to the required telephone interface (e.g., telephone exchange analog line or PBX extension).

### 5.4.3 Cabling the FXS Analog Lifeline

The device's FXS Analog Lifeline feature provides a wired connection for a plain old telephone service (POTS) phone (FXS) to the PSTN / PBX (FXO) upon a power outage or IP network connectivity loss.

The FXS Analog Lifeline is available on the hardware configuration that provides a single FXO port and three FXS ports. The FXS lifeline phone connects to FXS port #1 and the PSTN/PBX connects to FXO port #1. When the Lifeline is activated, the FXS line automatically connects to the FXO line and calls between these entities can be established.

➤ **To cable the FXS Analog Lifeline:**

1. Connect the analog lifeline telephone to FXS port #1, located on the rear panel.
2. Connect an analog PSTN line to FXO port #1, located on the rear panel.

**Figure 5-14: Cabling the FXS Analog Lifeline**

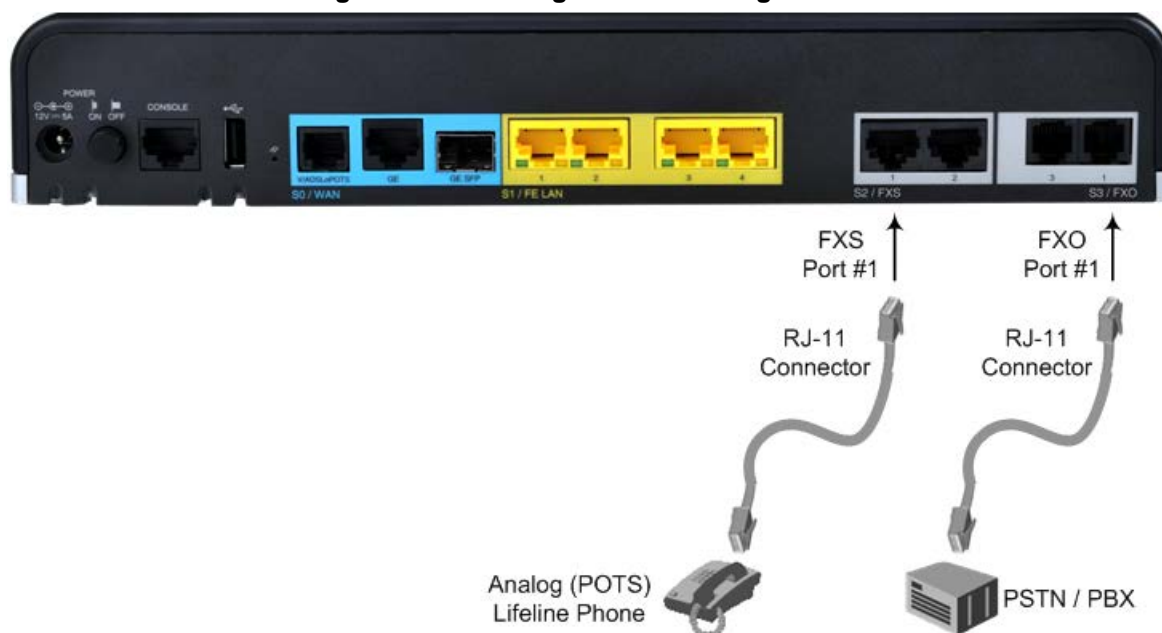

**Notes:**



- The FXS Analog Lifeline feature is a customer-ordered item, which is supported only on specific hardware configurations with combined FXS and FXO interfaces. For more information, contact your AudioCodes sales representative.
- The scenario upon which the FXS Analog Lifeline is activated is configured by the `LifelineType ini` file parameter. For more information, refer to the *User's Manual*.

## 5.5 Cabling the Serial Interface to a PC

The device provides an RS-232 serial interface port on its rear panel. The RS-232 interface port is used to access the device's command line interface (CLI). An RJ-45 to DB-9 serial cable adapter is supplied for serial cabling:

Figure 5-15: RS-232 Cable Adapter

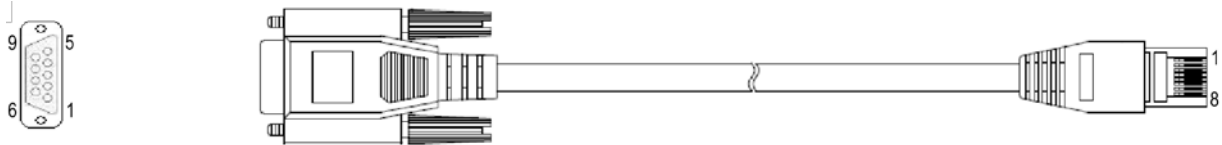

Table 5-4: RJ-45 to DB-9 Serial Cable Connector Pinouts

| RJ-45 | DB-9 Female |
|-------|-------------|
| 1     | 8           |
| 2     | 6           |
| 3     | 2           |
| 4     | 5           |
| 5     | 5           |
| 6     | 3           |
| 7     | 4           |
| 8     | 7           |

➤ **To connect the device's serial interface port to a PC:**

1. Connect the RJ-45 connector at the end of the cable to the device's serial port, located on the rear panel and labeled **CONSOLE**.

Figure 5-16: Cabling Serial Port

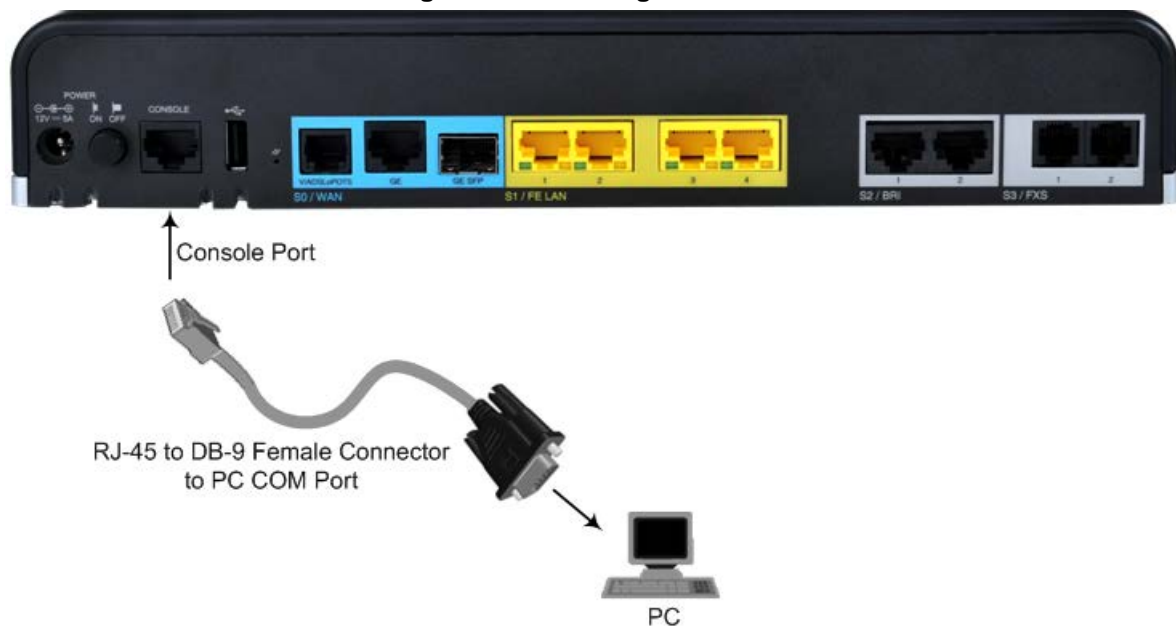

2. Connect the 9-pin DB connector at the other end of the cable to the COM RS-232 communication port on your computer.

## 5.6 Connecting a USB Storage Device

The device supports USB storage capabilities, using an external USB hard drive or flash disk (disk on key) connected to the device's USB port. The storage capabilities are configured through CLI and include the following:

- Saving network captures to USB
  - Upgrading the device's firmware from USB
  - Updating the device's configuration from USB
  - Saving the current configuration to USB
- **To connect the USB storage device:**
- Connect the USB storage device to the USB port, located on the rear panel.

**Figure 5-17: Connecting USB Storage Device**



**Note:** Only a single USB storage (formatted to FAT/FAT32) operation is supported at any given time.

## 5.7 Connecting to the Power Supply

The device is powered by an external 12V AC/DC power adapter (supplied), connected to a standard alternating current (AC) electrical wall outlet. The type of AC/DC power adapter depends on the required amperage:

- 3A power supply – see Section 5.7.1 on page 39
- 5A power supply – see Section 5.7.2 on page 42

**Table 5-5: Power Specifications**

| Item                  | Description   |
|-----------------------|---|
| <b>Power Supply</b>   | Single universal external AC power supply   |
| <b>Input Ratings</b>  | 100-240 VAC, 50-60 Hz   |
| <b>Output Ratings</b> | One of the following, depending on customer requirement: <ul style="list-style-type: none"> <li>■ 12V/3A</li> <li>■ 12V/5A</li> </ul> |



**Warning:** Use only the AC/DC power adapter supplied with the device.

### 5.7.1 3-Amp Power Supply Cabling

For 3-Amp power supply, the device is shipped with the AC/DC power adapter shown in the figure below. The power adapter also supports interchangeable plugs to suite the electrical wall outlet type requirement of the country in which the device is being installed.

**Figure 5-18: 3A AC/DC Power Adapter**

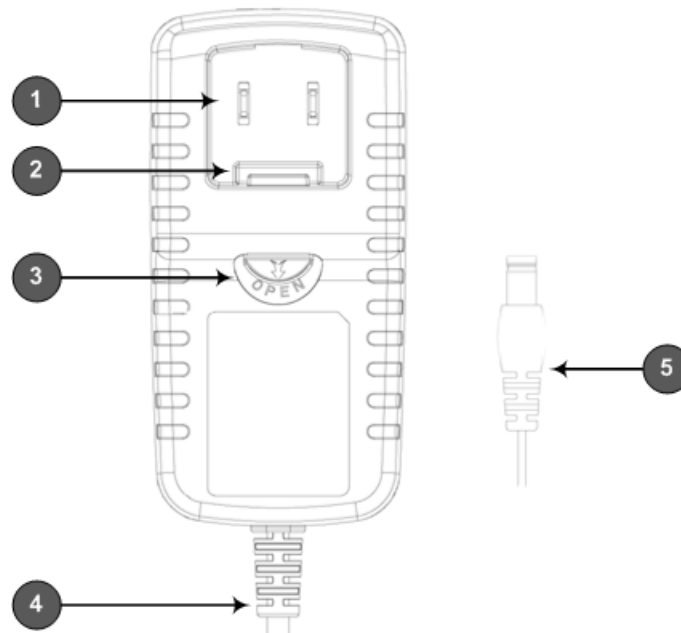
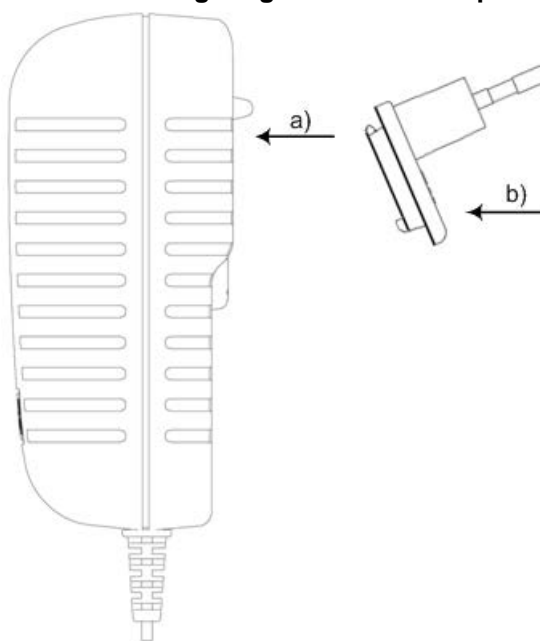

**Table 5-6: Power Adapter with Interchangeable Plugs**

| Item | Description        |
|------|--------------------|
| 1    | Plug slot          |
| 2    | Plug lock          |
| 3    | Plug release lever |
| 4    | DC power cord      |
| 5    | DC power plug      |

➤ **To connect the device to the power supply using the 3-Amp power adapter:**

1. Insert the relevant AC plug into the housing power adapter:
  - a. Insert the top part of the plug into the upper part of the housing slot (1).
  - b. Press down on the bottom part of the plug until a "click" sound is heard, indicating that the plug is securely inserted in the housing slot. To remove the plug, push and slide down the OPEN plug release lever (3).

**Figure 5-19: Inserting Plug into Power Adapter**



2. Insert the DC plug (5) located at the end of the power cord (4) of the power adapter into the device's power socket located on the rear panel.

**Figure 5-20: Cabling to Power with 3A AC/DC Power Adapter**

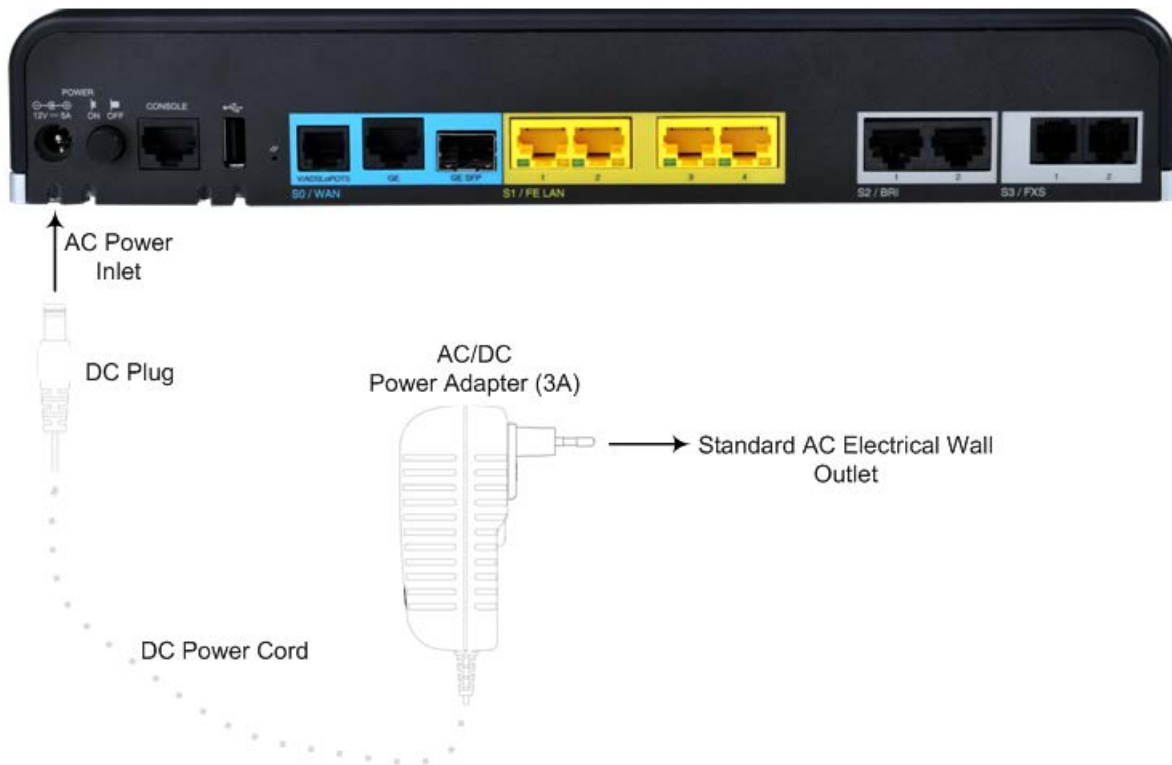

3. Plug the power adapter directly into a standard electrical wall outlet.

## 5.7.2 5-Amp Power Supply Cabling

For 5-Amp power supply, the device is shipped with an AC/DC power adapter that supplies 5 amps. The adapter provides an integrated DC power cord with a DC plug for attaching to the device. For the connection to the standard AC electrical wall outlet, an AC power cord with a female, 2-prong plug (C2) on one side for connecting to the AC/DC adapter and a plug on the other end for connecting to electrical wall outlet

➤ **To connect the device to the power supply using the 5-Amp power adapter:**

1. Connect the DC plug at the end of the DC power cord to the device's power socket, located on the rear panel.
2. Connect the 2-prong plug at one end of the AC power cord to the power adapter.

**Figure 5-21: Cabling to Power with 5A AC/DC Power Adapter**

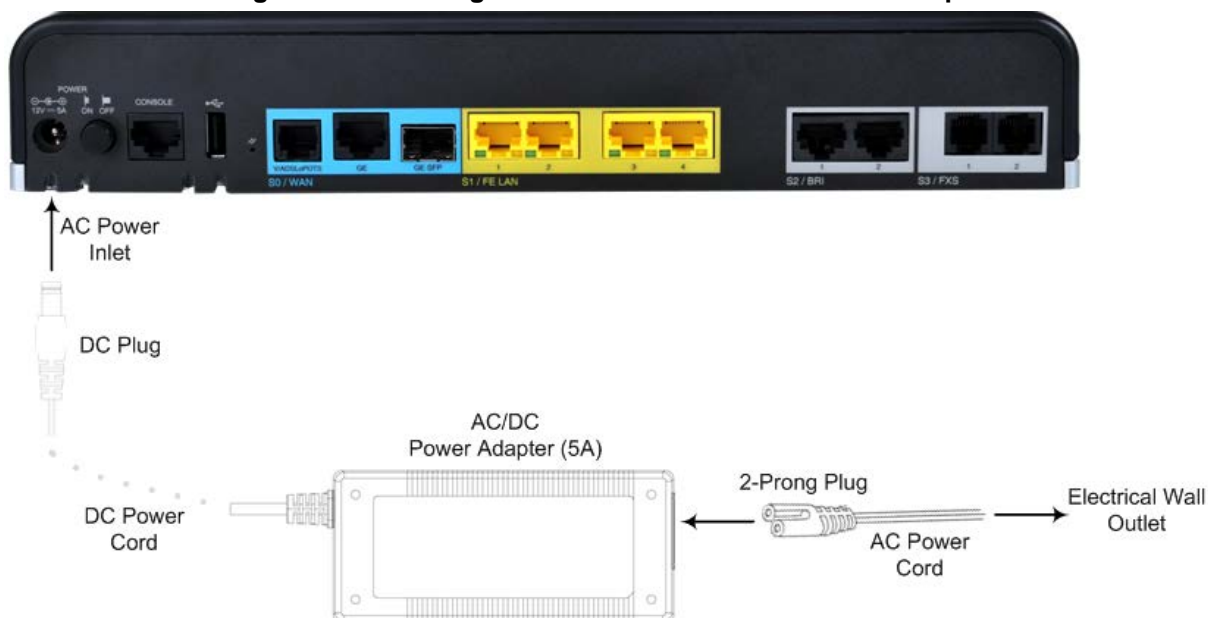

3. Connect the plug at the other end of the AC power cord to a standard electrical outlet.

## 5.7.3 Powering On or Off the Device

The device is equipped with a power switch, which is located on its rear panel (see Section 3.3 on page 19) for turning it on or off.

➤ **To power on the device:**

- Press in the power button; the device receives power, indicated by the lighting of the **Power** LED, located on the front panel.

➤ **To power off the device:**

- Press out the power button; the device powers off, indicated by the **Power** LED going off.

## A Approved Laser SFPs

The table below lists the recommended SFPs, which can be ordered from AudioCodes. For installing the SFPs and for fiber-optic WAN cabling, see Section 5.1.2 on page 25.

**Table A-1: Approved SFP Modules**

| Object / Part No.                 | Manufacturer / Trademark | Optional Types / Models  | Technical Data   | Standard (Edition / Year)  | Mark(s) of Conformity   |
|-----------------------------------|--------------------------|--|--|--|---|
| <b>Laser SFP Insert</b>           | Source Photonics         | <ul style="list-style-type: none"> <li>▪ SPL-35-03-EBX-CDFM</li> <li>▪ SPL-53-03-EBX-CDFM</li> <li>▪ SPL-35-03-EBX-CDFM</li> <li>▪ SPL-34-GB-BX-CDFM</li> <li>▪ SPL-43-GB-BX-CDFN</li> <li>▪ SP-GB-LX-CDFN</li> <li>▪ SP-GB-SX-CDFB</li> </ul> | Class 1 <ul style="list-style-type: none"> <li>▪ 1310 nm</li> <li>▪ 1550 nm</li> <li>▪ 1850 nm</li> <li>▪ 1490 nm</li> </ul> | <ul style="list-style-type: none"> <li>▪ EN60950-1:2006+A11</li> <li>▪ EN60825-1:2007, EN60825-2:2004+A1</li> <li>▪ UL60950-1</li> </ul>           | <ul style="list-style-type: none"> <li>▪ UR</li> <li>▪ TUV</li> </ul> |
| <b>Alternate Laser SFP Insert</b> | Neo Photonics            | <ul style="list-style-type: none"> <li>▪ PT7320-51-1W+</li> <li>▪ PTB3350-3331W-LC/PC+</li> <li>▪ PTB3530-3331W-LC/PC+</li> <li>▪ PTB3370-553CW-LC/PC+</li> <li>▪ PTB3830-553CW-LC/PC+</li> <li>▪ PT7320-51-1W+</li> </ul>                     | Class 1 <ul style="list-style-type: none"> <li>▪ 1310 nm</li> <li>▪ 1550 nm</li> <li>▪ 1850 nm</li> <li>▪ 1490 nm</li> </ul> | <ul style="list-style-type: none"> <li>▪ EN60950-1:2006+A11</li> <li>▪ EN60825-1:2007</li> <li>▪ EN60825-2:2004+A1</li> <li>▪ UL60950-1</li> </ul> | <ul style="list-style-type: none"> <li>▪ UR</li> <li>▪ TUV</li> </ul> |

**International Headquarters**

1 Hayarden Street,  
Airport City  
Lod 7019900, Israel  
Tel: +972-3-976-4000  
Fax: +972-3-976-4040

**AudioCodes Inc.**

27 World's Fair Drive,  
Somerset, NJ 08873  
Tel: +1-732-469-0880  
Fax: +1-732-469-2298

**Contact us:** [www.audiocodes.com/info](http://www.audiocodes.com/info)

**Website:** [www.audiocodes.com](http://www.audiocodes.com)



Document #: LTRT-10444